



Smart Security IP Intercom IS/IV 720 User Manual



IS720-01



IV720-01



IS720TD-01



IV720TD-01

Copyright and Disclaimer

Copyright

Any enterprises or individuals cannot extract, copy and spread in any form of this document without our written permission .In accordance with the law, copying includes translating the document into other languages or conversing into other formats. When this document is transmitted in network media, Escene Communication Co. , Ltd allows downloading or printing for private use. Any parts of the document are not allowed to be modified or used for commercial purposes. Escene Communication Co. , Ltd will not assume any responsibility for the injuries and losses caused by any unauthorized modification or conversion of the document.

Declaration

Information regarding this guide is subject to change without any notice.

This manual provides accurate statement, information and recommendation to the largest extent, but will not guarantee any express or implies. Users should take full responsibility for the application of products. Escene Communication Co. , Ltd will not make any guarantee for this manual, including but not limited to warranties for implies merchantability and particular purposes. Escene Communication Co. , Ltd does not assume any responsibility for indirect or consequential loss caused by the misuse of this manual.

About this manual

Thank you for choosing Smart Security IP Intercom IS/IV 720.This IP Intercom is specially designed for the user under the public environment with fashionable appearance and complete functions. This manual aims to help you quickly use Smart Security IP Intercom IS/IV 720.Before use ,please read the packing list and safety notes section of this manual ,communicate with the system administrator to confirm if the current network environment can meet the requirements of configuring the Intercom. If this is your first time to use Smart Security IP Intercom IS/IV 720, we recommend that you should read the quick installation guide and product technical manual. The document can be downloaded from the following website: <http://www.escene.cn/en/en>.

Summary

Copyright and Disclaimer.....	2
1. Getting Started.....	5
1.1 Outline.....	5
1.2 Product Features.....	5
1.3 Technical Information.....	6
2. Intercom Installation.....	7
2.1 Embedded.....	10
2.2 Equipment installation.....	12
3. Configuration of IP intercom.....	13
3.1 Remote WEB Management.....	14
3.2 Phone Status.....	17
3.3 Network.....	18
3.3.1 LAN Port Configuration.....	18
3.3.2 PC Port Configuration.....	19
3.3.3 VLAN Settings.....	19
3.3.4 Port management Settings.....	20
3.3.5 QoS.....	20
3.3.6 Network Packet Mirroring.....	20
3.3.7 LLDP.....	20
3.3.8 Paging Settings.....	20
3.3.9 Socket5 Proxy Server.....	21
3.4 SIP Accounts.....	22
3.5 Programmable Keys.....	24
3.6 Phone Settings.....	25
3.6.1 Output.....	25
3.6.2 Time Settings.....	26
3.6.3 Backlight.....	26
3.6.4 Ring tone.....	26
3.6.5 Volume Setting.....	27
3.7 Features.....	27
3.7.1 VoIP Call Forward.....	28
3.7.2 Auto Redial.....	28
3.7.3 Pickup function.....	28
3.7.4 Hotline function.....	28
3.7.5 Auto Answer.....	29
3.7.6 Remote Control.....	29
3.7.7 Action URL.....	29
3.7.8 EP+.....	29

- 3.7.9 Other features settings.....30
- 3.8 Advanced.....31
 - 3.8.1 Audio.....31
 - 3.8.2 Dial Plan.....31
- 3.9 Phone call info.....31
- 3.10 Door card setting.....32
- 3.11 Maintenance.....32
 - 3.11.1 HTTP Upgrade.....32
 - 3.11.2 FTP Upgrade.....33
 - 3.11.3 TFTP Upgrade.....33
 - 3.11.4 Factory reset.....34
 - 3.11.5 Reboot.....34
 - 3.11.6 Log.....35
 - 3.11.7 Auto Provision.....35
- 4. Relay management.....37
 - 4.1 RFID Card management.....38
 - 4.1.1 RFID Card issuing/revoking in the WUI of the phone.....38
 - 4.1.2 Add card Issuer and Revocation.....39
 - 4.2 Press key/Input/ServerControl/DTMF/TouchKey management.....40
- 5. Brief pictures for application environment.....40
 - 5.1 Door security system application.....41
 - 5.2 Fire protection system application.....41

1. Getting Started

1.1 Outline

ESCENE SN-SG IP Door Phone IS/IV 720, is the newest indoor VoIP intercom which professional designed as the requirements from industry users. The device has the characteristic of well compatibility with different platform, offering users a convenient service.



IS/IV 720 is dust proof, water proof and dismantle prevention, having a fashion appearance and high protection. IS/IV 720 is a bond of door opening by long-distance DTMF, Password and RFID. Its powerful performance, stability and reasonable price make it a perfect choice of industry user.

NOTE: IS/IV 720-PRT, P is POE, R is Reader(optional), T is Touchpad(optional).

1.2 Product Features

- Support embedded or wall-mounted installation.
- High-fidelity sound quality, HD codec, Full duplex hands-free calls;
- WEB supports multi-language: Chinese, Russian, French, etc.
- 4 SIP accounts, support 3-way conferencing;
- 2*RJ45 standard Ethernet Ports(LAN/PC), Support PoE;
- Backlit Digital Keyboard, can provide dial-up or password input(Option);
- *Built-in RFID reader; Indoor open-door interface and external power supply interface;
- User-defined DSS keys, which can be set up to Speedy dial, intercom, etc.
- Support Plug-and-Play, auto-provision, remote maintenance and management;

1.3 Technical Information

Intercom features
WEB support Multi-Language ;4 SIP account; Hotline; Call hold, Call waiting, Call forward; Call transfer (blind/busy/ask);Mute, DND; Auto-answer, 3-way conferencing;1 DSS programmable key(Speed dial, Intercom etc.);Volume control; Direct IP call without SIP proxy; Default Ring tone 1 selection/import/delete; Custom Ring tone 2 selection/import/delete; Time setting(SNTP/SIP Server/Manual);Support SIP main/standby server;
LED Status
Available--OFF ; Busy--Steady ; registration failed--Flashing
Network parameters
SIP v1 (RFC2543), v2 (RFC3261);DNS SRV (RFC3263);NAT Traversal: STUN mode; DTMF: In-Band, RFC2833, SIP Info, Auto; HTTP/HTTPS Web Management; IP Assignment: Static/DHCP/PPPoE; Network support Bridge mode; TFTP/DHCP/PPPoE client; DNS client, NAT/DHCP server;
Security
LLDP, VLAN QoS (802.1pq),VPN(L2TP);Transport Layer Security (TLS);Digest authentication using MD5/MD5-sess;Secure configuration file via AES encryption; Admin/User 2-level configuration mode;
Voice features
Wideband Codec: G.722;Narrowband codec: G.711μ/A, G.723.1;G.726, G.729a/b, iLBC; VAD, CNG, AEC, AGC; Full-duplex;
Video features
Video codec: H.264 ; Image codec: JPEG/PNG/BMP/GIF; Video format: MP4/3GP/FLV; Video call resolution: QCIF / CIF / VGA / 4CIF (1280x720P); Bandwidth selection: 64kbps~4Mbps; Frame rate selection: 10~30fps.
Physical properties
1 Digital Keypad, backlit digital (Option) 1 LED display (LED digital tube, available in touchpad model) 1 Speaker Key or DSS key ; 1 Reader Light, 1 Ringing status Light, 1 Network & SIP Light 1 Talking status light 2 RJ-45 10/100M Ethernet Power adapter: DC 12V/1A; Power over Ethernet ,IEEE 802.3af,class 0; Each motherboard port, check the picture illustration below "Mother Broad Interface".
Carton packaging
The whole Size : 162*112*40mm
Product Certification
   ISO 9001
Platform Compatibility Test (non-certificate)
ZTE/Alcatel-Lucent/Asterisk/Broadsoft/Metaswitch/Yeastar/Avaya/3CX/Elastix/HUAWEI etc.

INTERFACE SPECIFICATION:

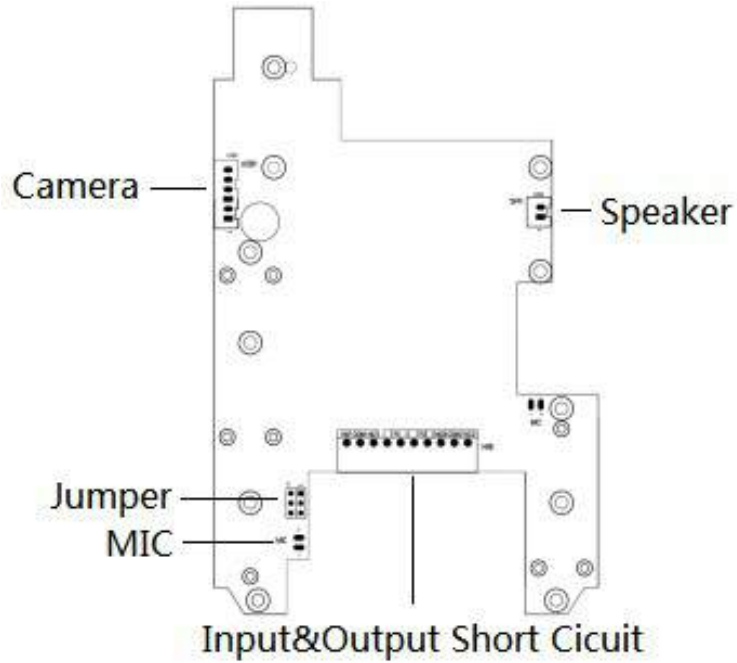

Expansion Board Connector Diagram

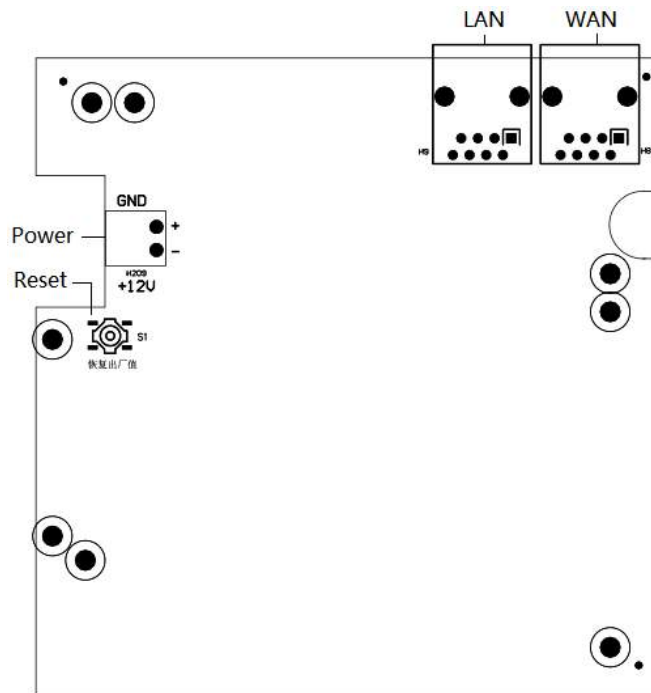

Mother Board Connector Diagram

*This data is for information purposes only and is subject to change without notice.

2. Intercom Installation







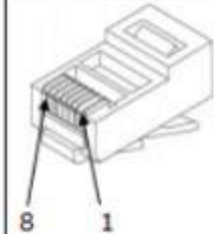

Generally system administrator will connect your new IS/IV 720 IP Intercom to company LAN network. If not, please refer to below illustration.

Open IS/IV 720 packing box, according to the packing list, check the related attachment to make sure to no omitting. Packing list as follows.

- IS/IV 720 Intercom
- Quick operating guide
- 8*Screws
- 2*Rubbers

IS/IV 720 could be installed to internet according to the below steps.

- A)Connect Network
- B)Internal/External Electric Lock Connection Driver Option
- C)Internal/External Electric Lock Connection

RJ-45				IS720	
	Pin No.	Marking	Colour	LAN	PC
	1	Tx+		TX1+	RX2-
	2	Tx -		TX1-	RX2+
	3	Rx+		RX1+	TX2-
	4	PoE+		POE+	Null
	5	PoE+			
	6	Rx -		RX1-	TX2+
	7	PoE-		POE-	Null
	8	PoE-			

Connect network

NOTE: When the initial electric current of the lock is less than 500mA/12V, you can access to the internal driven mode and use the POE of the Voice Access System or 12V DC to control the switch of the electric lock; When the initial electric current of the lock is more than 500mA/12V, you need to access to the external driven mode(Use specialized DC power to control the electric lock).

Electric lock power supply mode		Electric lock		Jumper	Mode of connection
Internal	External	NO	NC		
✓		✓			
	✓	✓			
✓			✓		
	✓		✓		

Internal/External Electric Lock Connection Driver Option

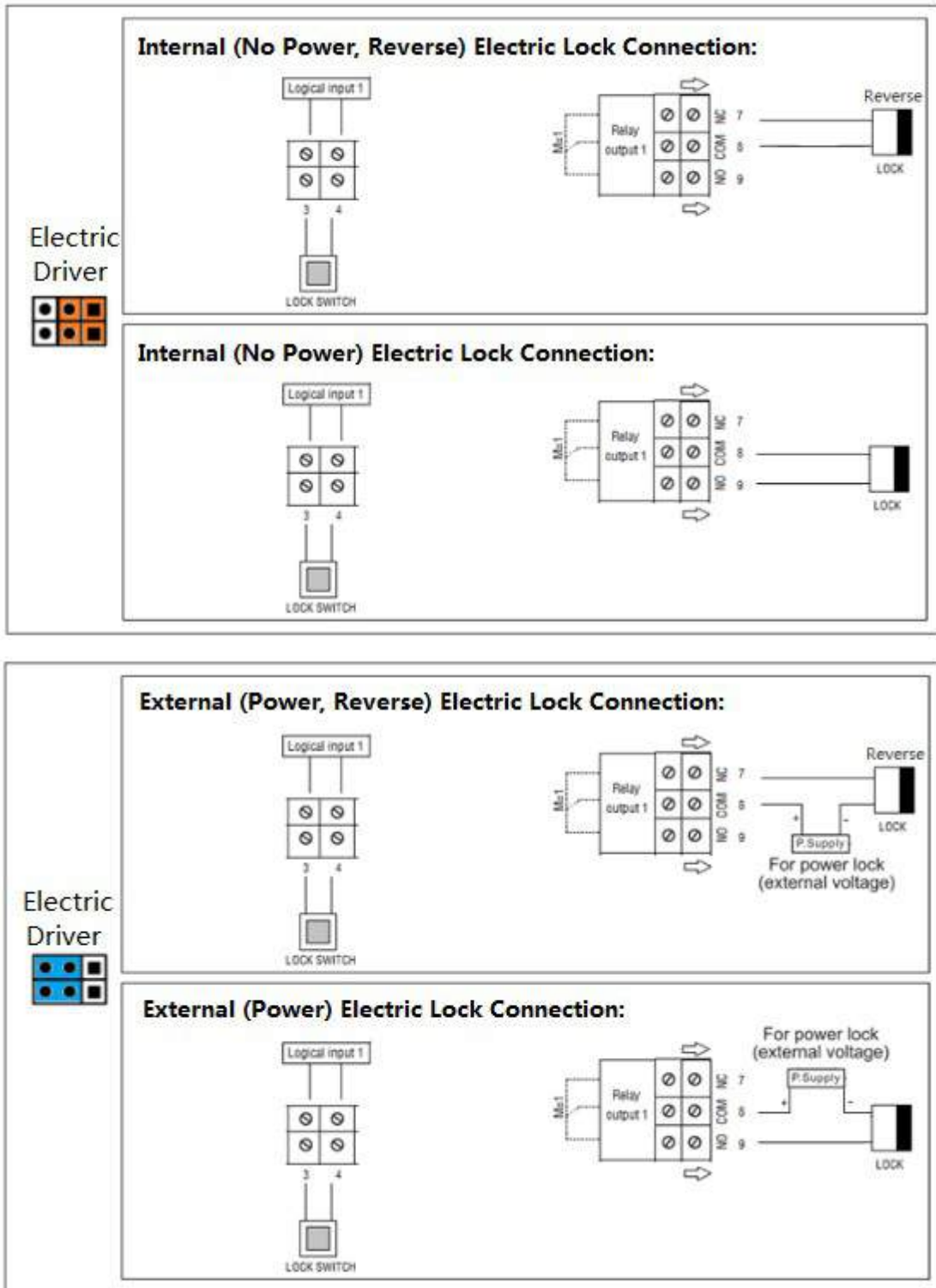

Internal/External Electric Lock Connection

2.1 Embedded

If the product is used for embedding, then the cutting of embedded need to be a little bigger than the installing hole of standard dimension 168*116*42mm .(42mm means the extra aluminum housing thickness.),as follows. Notice: the embedded value is up to the actual situation.

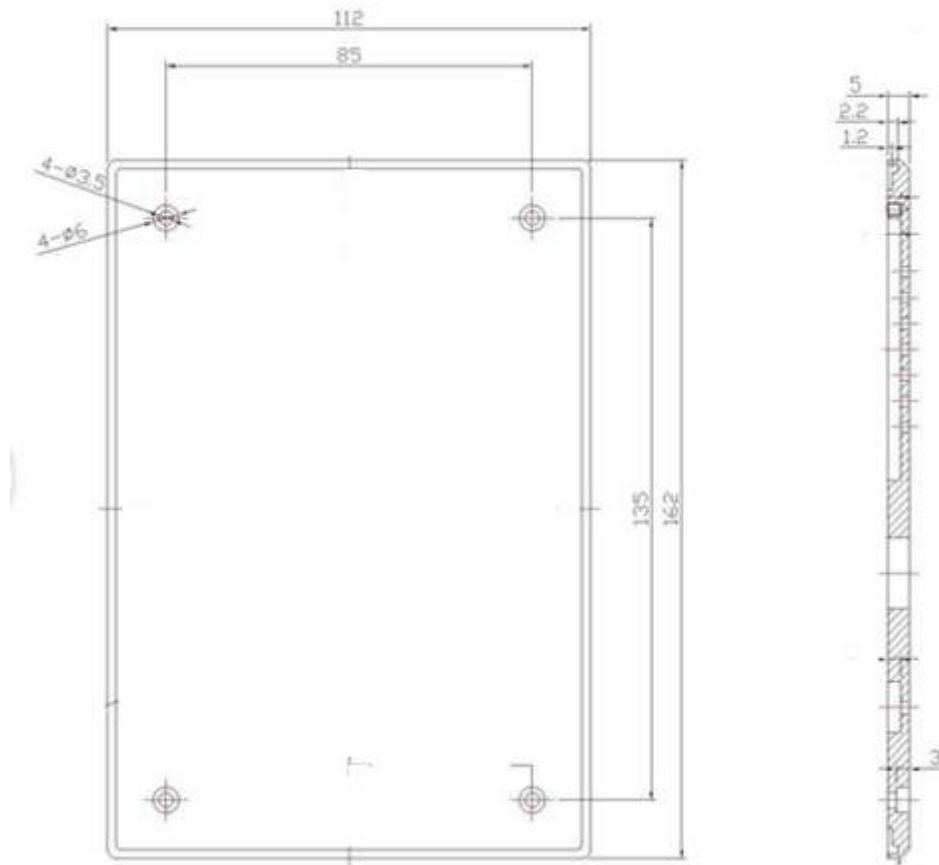

Front and side structure

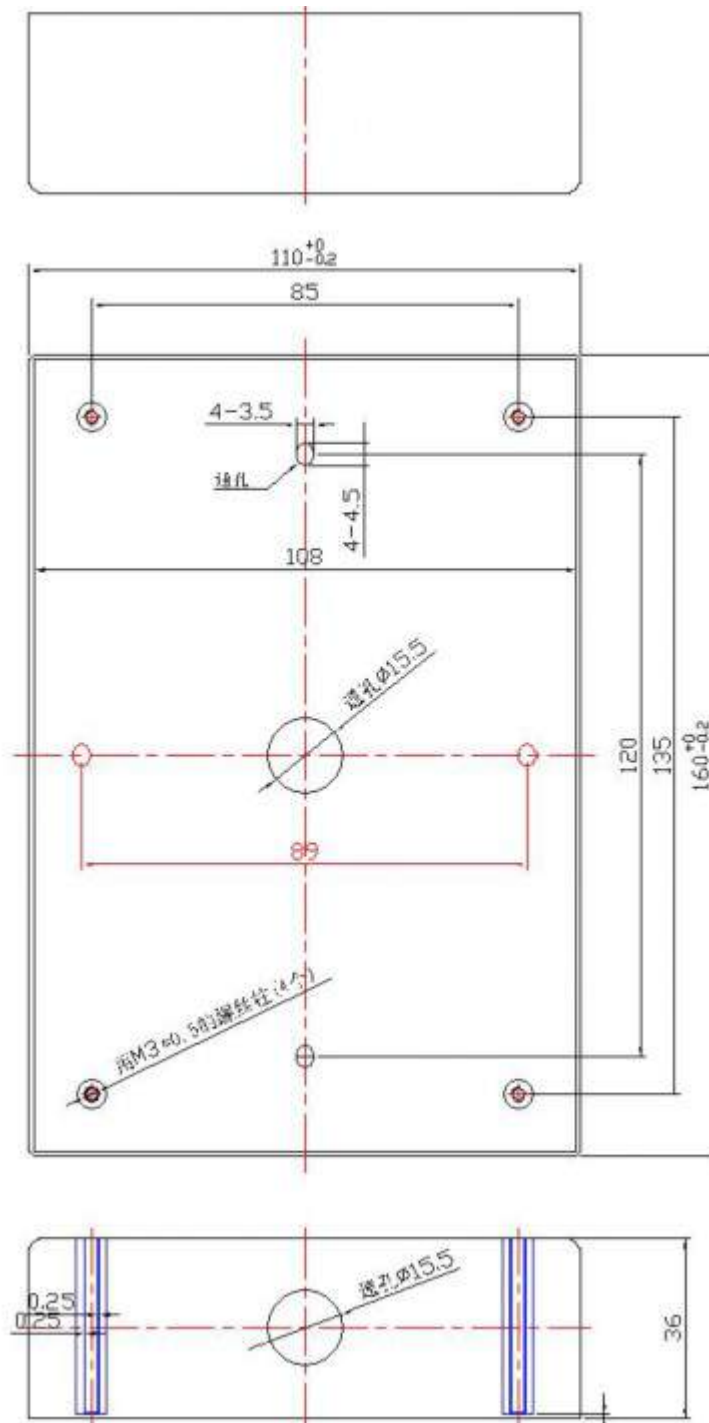

Back structure

2.2 Equipment installation

- 1、 Open the aluminum housing.
- 2、 Put the IP intercom into it according to the cutting embedded specification. After that, fix four M3*12 screws on the wall with the screw driver.

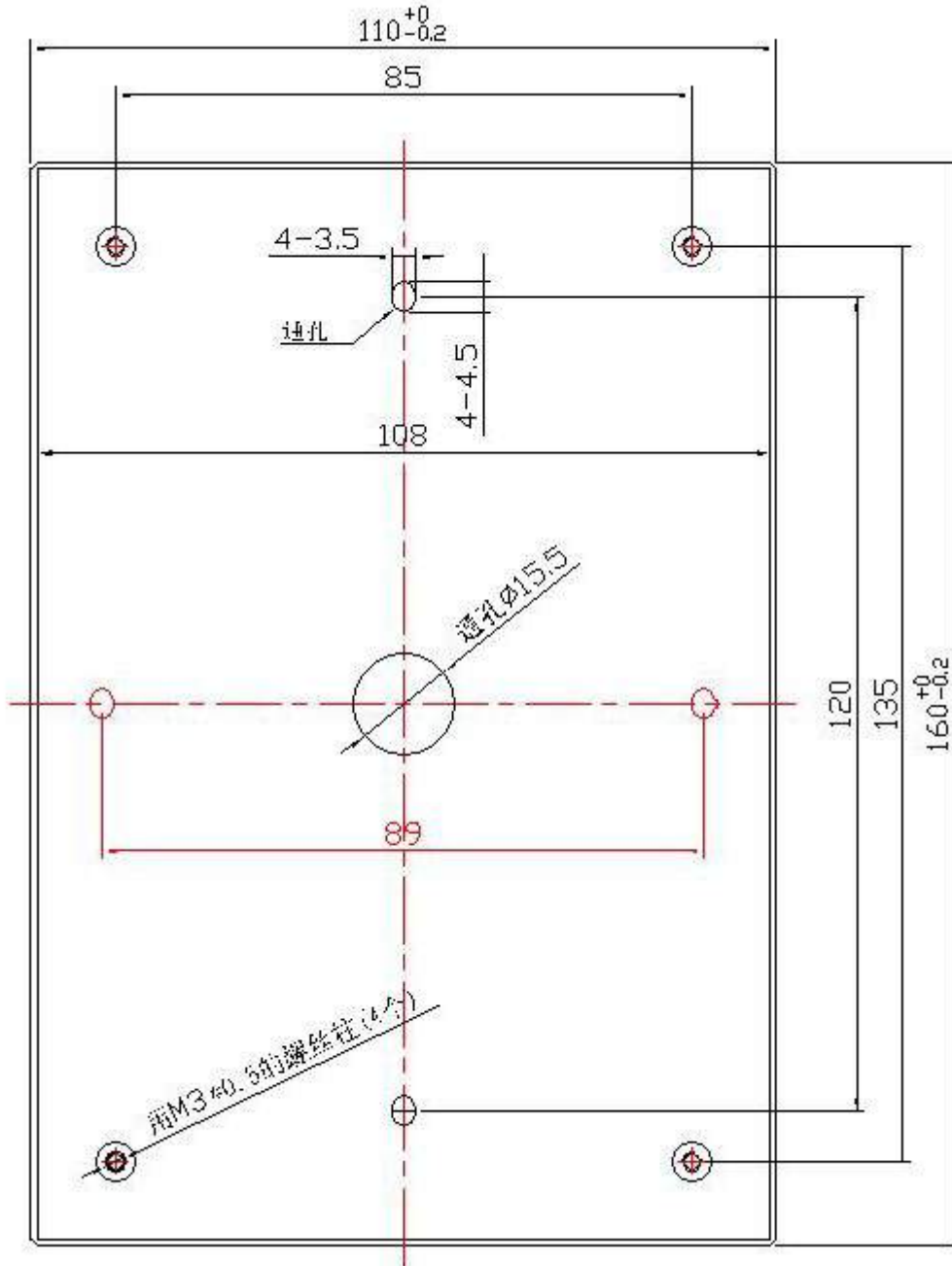

3、 After installing inter housing, well-set the related wiring and replace the aluminum housing. Power on and start testing.

3.Configuration of IP intercom

You need to know the IP address of IP Intercom before starting setting. You could learn how to get IP address below.Default IP address is 192.168.1.153.in static status.If getting from DHCP,you need to search the related IP address by the third software scanning equipment MAC.(Getting IP by DHCP is not suggested.)

3.1 Remote WEB Management

This equipment's factory IP address is using static IP(ip:192.168.1.100, Gateway:192.168.1.1).

http://192.168.1.100/user.asp is easy web management.

http://192.168.1.100/home.asp is all-round web management.

Once input the IP address of intercom on the web browser and tap the “enter” on the keyboard. Then a login screen will pop up from the intercom equipment. You need to input user name and password. Both default user name and password of system is case letters “root”



After the log-in , the easy administrate web page of the intercom will pop up.

Intercom Settings

Phone Status

System Run Time 0 Days0 Hours1 Minutes40 Seconds

Register status ?

Account1 **None**
 Account2 **None**
 Account3 **None**
 Account4 **None**

Network Status ?

LAN Port type Static
 MAC 00:26:8b:06:0e:9c
 LAN IP Address 192.168.1.100
 Subnet Mask 255.255.255.0
 Gateway 192.168.1.1
 Primary DNS 192.168.0.1

System Info ?

Phone Model IS/IV720
 Software Version V0.1.12.1007_Alpha(1064)
 Hardware version V2.x.x
 Kernel Version v1.0.0

Network

DHCP ?

Hostname(Option 12)
 Manufacturer(Option 60)
 User Class Information
(Option 77)

Static IP ?

IP Address
 Subnet Mask
 Gateway
 Static DNS on off
 Primary DNS
 Secondary DNS
 HTTP Port (1-65535)

SIP Account

Enable ?

Display Name ?

Username * ?

Password ?

SIP Server * ?

Polling interval time of registration s Default value: 32s, range: 20s~60s

Register Expiration Time Default: 3600s, Min: 40s ?

Phone Settings

Door Monitor Server URL

OutPut1 Press Key InPut1 InPut2 Server Control
 DTMF Number # DoorCard
 Touch key Open Door Number:
Short Circuit Time: s (1-3600)

OutPut2 Press Key InPut1 InPut2 Server Control
 DTMF Number: # DoorCard
 Touch key Open Door Number:
Short Circuit Time: s (1-3600)

Speakerphone volume (1~9)

Speakerphone mic volume(1~7)

Hot Number ?

Auto Answer off on

Phone Maintenance

Select a File 浏览...

Software Upgrade

Configuration

Default Settings

Reboot

If you want to open the all-round web management, you can enter an URL as follow:

 <http://192.168.1.100/home.asp>

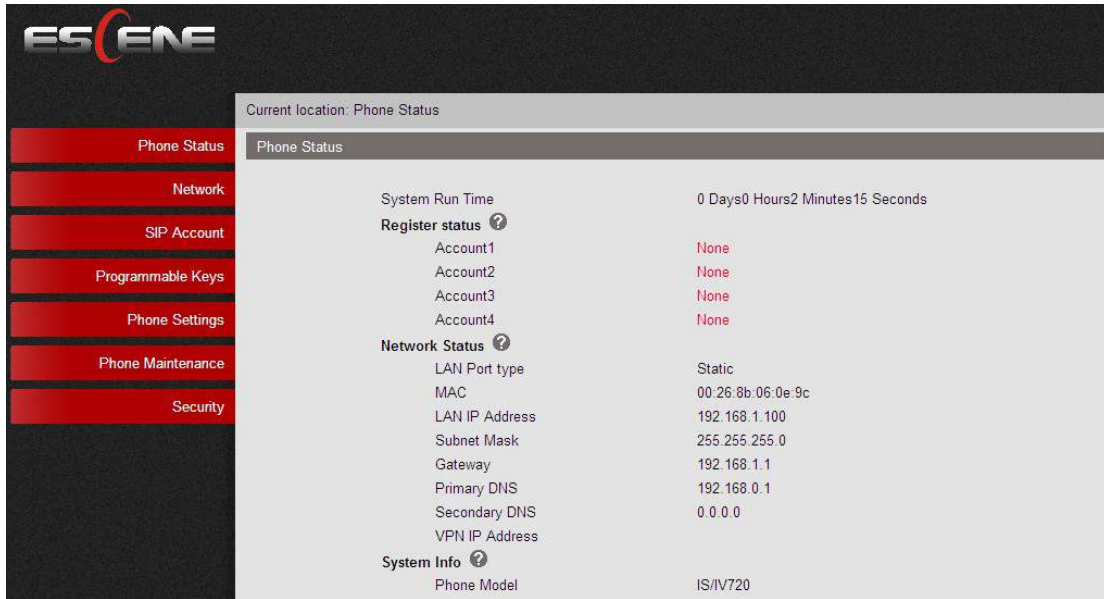

Here you can see as below information: System Run Time, Register Status, Network Status, System Information,

3.2 Phone Status

Here you can see as below information: System Run Time, Register Status, Network Status, System Information,

Current location: Phone Status

Phone Status

System Run Time	0 Days0 Hours2 Minutes15 Seconds
Register status ?	
Account1	None
Account2	None
Account3	None
Account4	None
Network Status ?	
LAN Port type	Static
MAC	00:26:8b:06:0e:9c
LAN IP Address	192.168.1.100
Subnet Mask	255.255.255.0
Gateway	192.168.1.1
Primary DNS	192.168.0.1
Secondary DNS	0.0.0.0
VPN IP Address	
System Info ?	
Phone Model	IS/IV720
Software Version	V0.1.15.0118_Alpha(1305)
Hardware version	V2.x.x
Hardware ID	0
Kernel Version	v1.0.0
Auto Provision Server URL	voip.autoprovision.com
TFTP Server IP	voip.autoprovision.com

Refresh

3.3 Network

3.3.1 LAN Port Configuration

DHCP 

Hostname(Option 12)

Manufacturer(Option 60)

User Class Information(Option 77)

Static IP 

IP Address

Subnet Mask

Gateway

Static DNS on off

Primary DNS

Secondary DNS

PPPoE 

Username

Password

MTU Default: 1500

ITEM	DESCRIPTION
Network Connection Mode	Network Connection Mode has DHCP, Static IP, PPPoE.
DNS SETTINGS	Select the DNS mode that you want.

3.3.2 PC Port Configuration

Current location: Network > PC Port

PC Port

As bridge 

 As router 

IP Address *

Subnet Mask *

Router DHCP off on

Start IP address

End IP address

Bridge mode

Normally, you should choose “bridge” feature, it means that pc port and LAN port will share the same network.

Router mode

Router feature is for the phone PC Port. You must input IP address (it’s equivalent to a gateway) and Net mask. If you want to use DHCP function, please turn it on, input start IP and end IP.

3.3.3 VLAN Settings

VLAN Settings >>

LAN Port		PC Port	
Enable VLAN:	<input type="checkbox"/>	Enable VLAN:	<input type="checkbox"/>
VID:	<input type="text" value="0"/> (0~4094)	VID:	<input type="text" value="0"/> (0~4094)
Priority:	<input type="text" value="0"/> (0~7)	Priority:	<input type="text" value="0"/> (0~7)

When using VLAN Setting option, you can set several parameters as follow:

VLAN Setting	
Enable VLAN	You can enable/disable VLAN for phone and pc

VID [LAN/PC Port]	The VLAN ID you want the phone or pc to join
----------------------	--

3.3. 4 Port management Settings

Port Management Settings >>

HTTP Port (1-65535)

Telnet off on

Telnet Port (1-65535)

Local SIP port (Default: 5060)

RTP port range –

Please Note: After changing the default HTTP port 80, please restart the machine to take effect. Using the new HTTP port to access the Web user interface "http://ipaddr:port".

3.3. 5 QoS

Qos >> ?

SIP Qos (0-63)

Voice Qos (0-63)

3.3. 6 Network Packet Mirroring

Network Packet Mirroring >>

Network Packet Mirroring ▾

3.3. 7 LLDP

LLDP >>

LLDP off on

LLDP Packet Interval s(1-3600)

3.3. 8 Paging Settings

Paging Settings (NOTE: This feature priority is followed the serial number, In other words, "paging1" is the highest priority)

Paging Setting >>

Paging1 off on
 Group IP Port:

Paging2 off on
 Group IP Port:

Paging3 off on
 Group IP Port:

Paging4 off on
 Group IP Port:

Paging5 off on
 Group IP Port:

3.3.9 Socket5 Proxy Server

Socket5 Proxy Server >>

Socket5 Proxy Server off on
 Server IP *
 Port *
 Anonymous Login
 Username
 Password

Socket5 Proxy Server	
Socket5 Proxy Server	Enable/Disable Socket5 Proxy Server.
Server IP	Socket5 Proxy Server IP address.
Port	Socket5 Proxy Server port, default is 1080.
Anonymous Login	Enable/Disable Socket5 Proxy Server login username.

3.4 SIP Accounts

Current location: SIP Account >Account1

Enable	<input checked="" type="checkbox"/> ?
Server type	Default ▾
Display Name	<input type="text"/> ?
Username	3003 * ?
Authenticate Name	<input type="text"/> ?
Password	•••• ?
Label	<input type="text"/> ?
SIP Server	192.168.0.7 * ?
Secondary server	<input type="text"/> ?
Outbound Proxy Server	<input type="text"/> ?
Secondary Outbound Proxy Server	<input type="text"/> ?
Polling interval time of registration	32 s Default value: 32s, range: 20s~60s
NAT Traversal	Disabled ▾ ?
STUN Server	<input type="text"/> ?
Register Expiration Time	3600 Default: 3600s, Min: 40s ?
Auto Answer	<input type="radio"/> off <input checked="" type="radio"/> on
SIP Transport	<input checked="" type="radio"/> UDP <input type="radio"/> TCP <input type="radio"/> TLS ?
Ring type	None ▾ ?

Choose one Account, you will find the following parameters:

ITEM	DECSRIPTIO
Enable	You can choose on/off to enable/disable the line.
Account Mode	You can choose VOIP/PSTN, but this model nonsupport PSTN, If you need, Pls contact us to buy another model that can supports PSTN.
Display Name	It is showed as Caller ID when making a phone call
Username	It is a username provided by SIP Server
Authenticate Name	It is authenticated ID for authentication
Password	It is a password provided by SIP Server
Label	Label with this account.
SIP Server	Server for registration, provided by administrator
Secondary server	When the main server can't work, it also can register in this secondary server.
Outbound Proxy	Put into the address with the outbound proxy server.

Secondary Outbound Proxy Server	When the main out bound server can't work, it also can use this secondary server.
Poling Interval Time Of Registration	Poling Interval Time Of Registration, default is 32 s.
NAT Traversal	De fines the STUN server will be active or not
STUN Server	Session traversal utilities for NAT.
BLA	Share with the line.
BLA Number	BLA Number
Subscribe Period	Subscribe expire time.
Register Expire Time	IP phone automatically registered every time
SIP Transport	There are UDP/TCP/TLS three options
Ring Type	Select this account ringing type.

Current location: SIP Account >Account1

Advanced >>

RPort off on ?

Do not Disturb off on

Anonymous call off on ?

Anonymous Call Rejection off on ?

Use Session Timer off on ?

Session Timer (min: 30s) ?

Refresher ?

Call Method SIP TEL

DNS-SRV off on

Allow-events off on

Registered NAT off on

Keep-alive Type ▾

Keep-alive Interval (15-60s)

Use user=phone off on ?

BLA off on ?

BLA Number

Subscribe Period Default: 1800s, Min: 120s ?

SIP Encryption off on ?

Encryption algorithm ▾

Encryption key

Voice encryption (SRTP) ▾ ?

EP+ Outcode Switch off on

OutCode

OutCode Length

ITEM	DECSRIPTIO
Call	
Do Not Disturb	Enable/Disable Do Not Disturb
Anonymous Call	Enable/Disable anonymous call.
Anonymous Call Rejection	Enable/Disable anonymous call rejection.
Use Session Timer	Enable/Disable refresh session function. The device will send an Invite packet to refresh the session during a call if it enable.
Session Timer	The refresh session time interval.
Call Method	This method include SIP and TEL.
DNS-SRV	Enable/Disable DNS-SRV.
Allow-events	Enable/Disable Allow-events.
Registered NAT	Enable/Disable Registered to NAT

UDP Keep-alive Message	The phone periodically sends a UDP packet to keep the port active and to avoid the server to shut down the port
UDP Keep-alive Interval	Default is 30 second.

ITEM	DECSRIPTIO
Security	
SIP Encryption	Enable/Disable SIP encryption.
RTP Encryption	Enable/Disable RTP encryption.
Encryption Algorithm	The encryption algorithm at this time we only have RC4.
Encryption Key	The key with encryption.

3.5 Programmable Keys

Current location: Programmable Keys >Memory keys

Memory keys

Key1: Mode Account Name Number

Speed Dial Account1

Submit

ITEMS	DESCRIBES
Line	The default value.
Speed Dial	You can use this key feature to speed up dialing the numbers often used or hard to remember.
Speed Dial Prefix	You can use this key feature to speed up dial a call with a specified prefix number.
DTMF	You can use this key feature to send the specification of arbitrary key sequences via DTMF.
BLF	You can use the BLF feature to monitor a specific user for status changes on the phone.
Paging	You can use multicast paging to quickly and easily forward time sensitive announcements out to people within the multicast group.
Call Park	You can use call park feature to place a call on hold, and then retrieve the call from another phone in the system (for example, a phone in another office or conference room).
Intercom	You can press the configured intercom key to automatically connect with a remote extension for outgoing intercom calls, and the remote extension will automatically answer the incoming intercom calls
BLA	This feature such as the BLF.

NOTE: ONLY WHEN YOU CHOOSE "SPEED DIAL", THE RIGHT OF

“NAME”, “NUMBER” WILL TAKE EFFECT.

3.6 Phone Settings

3.6.1 Output

Signal output 1&2 is controlled by several variables. Among them, Server control is a custom variable for some specified platforms. Once custom option is selected, Output variable will be activating accordingly.

Note: Both ‘signal input’ and ‘signal output’ are on/off switch

OutPut >>

Door Monitor Server URL

OutPut1 Press Key InPut1 InPut2 Server Control

DTMF Number

Short Circuit Time: s (1-3600)

OutPut2 Press Key InPut1 InPut2 Server Control

DTMF Number:

Short Circuit Time: s (1-3600)

Output1	Variables for output1
output2	Variables for output2
Press key	Press the dial button to trigger the relay.
Input1/2	Shortcut the input1 logic to trigger the relay. See the diagram
Server Control	Use API command to trigger the relay. Ask us for dev manual please.
DTMF Number	Pressing DTMF key to trigger the relay when the phone talking.
Short Circuit time	The relay circuit timer.

3.6.2 Time Settings

Time Settings >>

Set time mode

Time zone-GMT

Daylight Savings Time mode always off always on Auto

Update Interval (seconds) Seconds

ITEM	DECSRIPTIO
Time Settings	
Set Time Mode	Include SNTP/SIP Server/PSTN/Manual

SNTP Server	You can select in the list or input owner server address.
Update Interval	The update interval with SNTP.
Day Light Saving Time	Enable/disable the DST for the phone
Time Format	You can use 24 hour time format or 12 hour time format
Date Format	You can choose the appropriate time format.
Time Zone-GMT	You can select different time zone for the phone
Manual Setting	Setting time manually.

3.6.3 Backlight

Backlight >>

Backlight off Always On Timer s (Min:1, Max:255) ?

3.6.4 Ring tone

Ring1 is for the speaker on the panel, Ring2 is for external speaker

Note : Only Support a ring tone with G711A (*.wav) audio coding, maximum is 10 rings and the total size must be less than 150kB.

Ring >> ?

Ring type

Ring type2

Upload ring tone

(Please upload a ring tone with G711A(*.wav) audio coding, maximum is 10 rings and the total size must be less than 150kB.)

3.6.5 Volume Setting

You can manage the volume level and mic level as below form.

Note: Normally if the mic is on level 7. Please keep the volume below level 4. Unless the using area is small or you have good ability of noise reduction.

Volume Settings >>

Tone ?

Select country United States ▾

Ring volume(0~9)

The nightBegin time: -

Ring Volume in Night(0~9):

Output volume(1~9)

Speakerphone volume

Input volume(1~7)

Speakerphone mic volume

ITEM	DECSRIPTIO
Basic	
Select Country	Select the country dial tone. Default is United States.
Ring Volume	The ring volume default is Lv3, the range is 0~9.
Handset Volume	The handset volume default is Lv5, the range is 1~9.
Speaker Phone Volume	The speaker volume default is Lv5, the range is 1~9.
Headset Volume	The headset volume default is Lv3, the range is 1~9.
Handset MIC Volume	The handset MIC volume default is Lv3, the range is 1~7.
Speaker Phone MIC Volume	The speaker MIC volume default is Lv3, the range is 1~7
Headset MIC Volume	The headset MIC volume default is Lv3, the range is 1~7

3.7 Features

Including VOIP call forward, pickup features. Hot line features, auto answer, remote control. Action URL. EP+. And other features settings.

3.7.1 VoIP Call Forward

VoIP Call Forwarding >>

Always off To voicemail To this number: ?

If Busy off To voicemail To this number: ?

If No Answer off To voicemail To this number: ?

Ring Frequency Seconds (Default: 15s, Max: 15s)

ITEM	DECSRIPTIO
Always	All ways transfer the call to others.
If Busy	If the phone was busy working, the call will be transfer to others.
If No Answer	If the phone was no answer, the call will be transfer to others.
Ring Frequency	The ring frequency with the VOIP Call Forward.

3.7.2 Auto Redial

Auto Redial >>

Auto Redial off on

Auto Redial Interval(1~300s)

Auto Redial Times(1-300)

3.7.3 Pickup function

Pickup function >>

Pickup function off on

Pickup code

3.7.4 Hotline function

Hot Line Function >>

Hot Line Function off Delay s (0-30)

Hot Number ?

IP Dail

3.7.5 Auto Answer

Default value is on, Values can be changed accordingly.

Auto Answer >>

Auto Answer off on Turn on Auto Answer Group: NONE ▾

3.7.6 Remote Control

A Third party is permitted to control this device

Remote Control >> ?

Action URI allow IP List ?

3.7.7 Action URL

The device will send orders to action URL initiative.

Action URL >> ?

Off Hook	<input type="text"/>	?
On Hook	<input type="text"/>	?
Incoming Call	<input type="text"/>	?
Outgoing call	<input type="text"/>	?
Established	<input type="text"/>	?
Terminated	<input type="text"/>	?

3.7.8 EP+

EP+ options are for the users who download the EP+ application on mobile phone.

After Completing below settings, EP+ will be activated. For more details, please refer to www.escene.cn/en/en

EP+ >>

Configure Mode Automatic Manual

EP+ off on

Password

OutCode

OutCode Length

Door bell Code

Open Door Password

Roaming Server Address :

3.7.9 Other features settings

For other features such as Call waiting, DTMF etc.

Other Features Settings >>

Call Waiting off on ?

Call Waiting Tone off Play on currently active device Frequency: s (5-60) ?

Play Hold Tone off Play on currently active device Frequency: s (5-60) ?

DTMF RFC 2833 Inband SIP Info Auto ?

Suppress DTMF Display off on ?

100 Reliable retransmission off on ?

Play Hangup Tone off on

Conference Code off on Number:

Hold Code off on Number:

Conference exit result Disconnect all Others remain connected

Return code when refused ?

Return code when DnD ?

Called No Answer Time s (Min:20, Max:1800)

Caller No AnswerTime: s (Min: 90s, Max: 1800s)

RFC 2833 PayLoad

Caller ID source

SIP Session Timer(seconds) T1 ?

SIP Session Timer(seconds) T2 ?

SIP Session Timer(seconds) T4 ?

Affiliated Port off on

3.8 Advanced

3.8.1 Audio

For Audio Codecs setting and Jitter Buffer setting.

Audio >>

Audio Codecs ?

Up G711A G711U iLBC disabled Codecs
 G729 G722 G723 << G726_32 >>

Down

Jitter Buffer ?

Type Adaptive Fixed

Min Delay

Max Delay

Other

Payload length ms

High rate of G723.1

VAD ?

Echo suppression mode

Side Tone

3.8.2 Dial Plan

Dial Plan >>

Send key * #

Dial length (1~32)

No Dial timeout (1~14s)

ID	Operation	Prefix	IP Address	Account	Description
<input type="button" value="Add Rule"/> <input type="button" value="Delete all Rules"/>					
<input type="button" value="Submit"/>					

3.9 Phone call info

To call or hang up the phone via web

Current location: Phonebook > Phone Call Info

Phone Call Info

Dial a Number

Outgoing Account

3.10 Door card setting

For reader data mode setting, cards management and door log look-up

Current location: Phone Settings > DoorCard

Card Reader Setting

Card Reader Data SN ARN

State

Administrator Table

ID	Operation	Date	Type
000001112		Tue Dec 1 11:11:08 2015	Issuer
00008888		Tue Dec 1 11:11:19 2015	Revocation

Door Card Table

ID	Issuing Date	ARN Expiry Date

3.11 Maintenance

This part mainly introduces some maintenance method. According to the below, you can reconfigure Intercom IP Phone or view Intercom IP Phone log to gain more information about maintenance.

3.11.1 HTTP Upgrade

You can upgrade the software, kernel and configuration etc. files by HTTP.

Current location: Phone Maintenance > Basic

Basic (Attention: Do NOT power off when upgrading!)

HTTP Upgrade >>

Select a File	<input type="text"/> 浏览...
Software Upgrade	<input type="button" value="Upgrade"/>
Kernel Upgrade	<input type="button" value="Kernel Upgrade"/>
Configuration	<input type="button" value="Upload"/> <input type="button" value="Download"/>
Log	<input type="button" value="Download"/>
All Config Files	<input type="button" value="Download"/>

3.11.2 FTP Upgrade

You can upgrade the software, kernel and configure files by FTP.

FTP Upgrade >>

Server IP	<input type="text"/>
File name	<input type="text"/>
Username	<input type="text"/>
Password	<input type="text"/>
Software Upgrade	<input type="button" value="Upgrade"/>
Kernel Upgrade	<input type="button" value="Kernel Upgrade"/>
Note: It's not necessary to input a file name for backup.	
Configuration	<input type="button" value="Update"/> <input type="button" value="Backup"/>

When using FTP upgrade, you can set several parameters as follow:

FTP Upgrade	
Server IP	The IP address of the FTP server
Filename	Downloading from FTP server
Username	Providing by FTP server
Password	Providing by FTP server
Software Upgrade	Used for upgrading the software of the phone
Kernel Upgrade	Used for upgrading the kernel of the phone
Configuration	Used for updating/backup to update/backup the configure file of the phone

Phone Book	Used for updating/backup to update/backup the phonebook of the phone
EXT Module	Used for updating/backup the expansion of the phone [NOTES : The mode doesn't support this feature]

3.11.3 TFTP Upgrade

You can upgrade the software, kernel and configure files by TFTP.

TFTP Upgrade >>

Server IP

File name

Software Upgrade

Kernel Upgrade

Note: It's not necessary to input a file name for backup.

Configuration

TFTP Upgrade	
Server IP	The IP address of the TFTP server
Filename	Downloading from FTP server
Software Upgrade	Used for upgrading the software of the phone
Kernel Upgrade	Used for upgrading the kernel of the phone
Configuration	Used for updating/backup the configure file of the phone
Phone Book	Used for updating/backup the phonebook of the phone
EXT Module	Used for updating/backup the expansion of the phone [NOTES : The mode doesn't support this feature]

NOTES: It's not necessary to input filename when doing backup Configuration, Phone Book, EXT Module.

3.11.4 Factory reset

You can load the phone to the factory default setting in default setting option.

Default Settings >>

Click to confirm

Attention: restoring the phone to factory default will result in loss of service, accounts, and preferences that have been previously set by the user.

Press the 'Reset to Factory Setting' option, the phone will load to factory default setting on next reboot.

3.11.5 Reboot

You can use reboot option to reboot the phone.

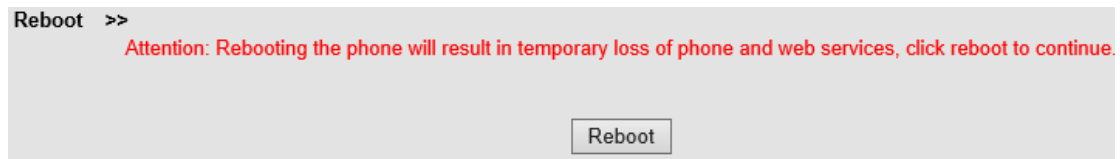

3.11.6 Log

This feature is use for the administrator to managing the equipment, like debugging, SIP etc,. If you need to catch a debugging Level, you need to setup on this interface.

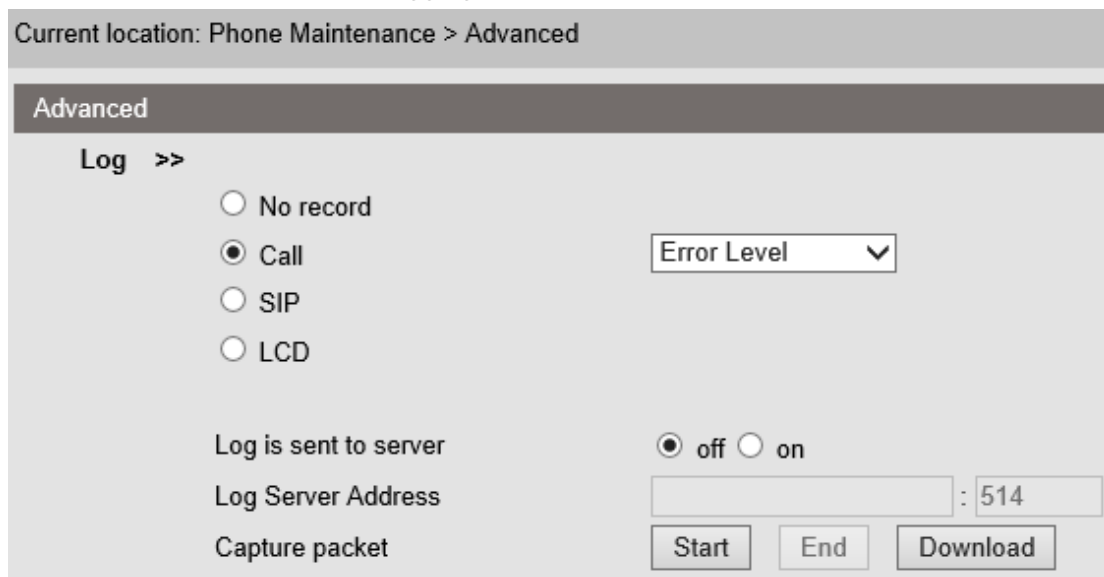

3.11.7 Auto Provision

When you open this auto provision feature, the phone will do auto provision after it detect a different software or kernel (Higher or Lower) which are putted on the TFTP,HTTP,HTTPS,FTP, server. For the detailed information about auto provision, you can find it in the official website: [HTTP://www.escene.cn/en](http://www.escene.cn/en)

Auto Provisioning >>

PNP active on off ?

PNP Interval (minutes)

Auto Provision on off

Option: (Default :66, Min:1, Max:254)

Protocol ▼

Software Server URL

Username

Password

Auto Download Software

Auto Download Kernel

Auto Download Config File

Booting Checked

Zero Active off on ?

Wait Time(1~100s) ?

Disable the phone while booting off on

Auto Provision Frequency Hours (Default :7 days, Max:30 days)

Auto Provision Time ▼

Next Auto Provisioning

AES Enabled off on

AES Key

Download file name ▼

When using auto provision, you can set several parameters as follow:

Auto Provision	
Auto Provision	You can enable/disable auto provision by select on/off
Protocol	Used for auto provision, it includes TFTP/HTTP/FTP
Software Server URL	The server address of the auto provision
Username	Providing by provision server
Password	Providing by provision server
Auto Download Software	Used for auto download software from server
Auto Download Kernel	Used for auto download kernel from server
Auto Download Config File	Used for auto download config file from server
Auto Download Expansion	NOTES: The model doesn't support this feature.
Auto Download Enterprise Phonebook	Used for auto download Enterprise Phonebook from server
Auto Download Personal Phonebook	Used for auto download personal phonebook from server
Booting Checked	Used for checking the auto provision when phone booting
Disable the phone while	Enable/Disable the booting checking feature.

booting checking	
Auto Provision Frequency	Used for setting the time interval for auto provision
Auto Provision Time	Used for the specific time for auto provision
Auto Provision Next Time	Reset the Auto Provision Next Upgrading time.
AES Enable	You can enable/disable AES encrypt for auto provision
AES Key	The key of the AES
Auto Provision Now	Used for doing auto provision immediately

4. Relay management

The IS/IV 720 supports RFID card, TouchPad password, physical button, DTMF, API command to trigger the relay.

PS: IS/IV 720-PRT, P=PoE, R=RFID Reader, T=TouchPad.

The screenshot shows the 'OutPut' configuration page. On the left, there is a navigation menu with 'Network' (selected), 'SIP Account', 'Phone Settings', and 'Basic'. The main content area is titled 'OutPut >>' and contains the following settings:

- Touch key Voice:
- OutPut1: Press Key InPut1 InPut2 Server Control
- DTMF Number: DoorCard
- Touch key Open Door Number:
- Short Circuit Time: s (1-3600)

Press key	Press the dial button to trigger the relay.
Input1/2	Shortcut the input1 logic to trigger the relay. See the diagram
Server Control	Use API command to trigger the relay. Ask us for dev manual please.
DTMF Number	Pressing DTMF key to trigger the relay when the phone talking.
Door Card	Using RFID Card trigger the relay.
Touch key Open	Pressing digit passwords to trigger the relay.
Short Circuit time	The relay circuit timer.

4.1 RFID Card management

Card Reader Setting

State

Administrator Table

ID	Operation	Date	Type
<input type="button" value="Add Administrator"/>			

Door Card Table

ID	Issuing Date	ARN Expiry Date
<input type="button" value="Refresh"/>		

State	Normal	Normal mode, the user can trigger relay by RFID card.
	Card Issuing	Manage mode, to add relay permission for RFID card.
	Card Revoking	Manage mode, to remove relay permission for RFID card.

4.1.1 RFID Card issuing/revoking in the WUI of the phone

Card Issuing steps:

- Set card reader state=Card Issuing.
- Put the RFID card in the reader of the phone, you'll hear the voice "du~".
- Refresh the web, you'll see there's a new message in the "Door Card table"
- Now you can use this card to trigger the relay.

Card Revoking steps:

- 1) Set card reader state=Card Revoking.
- 2) Put the RFID card in the reader of the phone, you'll hear the voice "du~".
- 3) Refresh the web, you'll see there's a message loose in the "Door Card table"
- 4) Now this card was removed, it could not trigger the relay any more.

PS: Must remember to set card reader state=Normal when finishing configuration.

4.1.2 Add card Issuer and Revocation

Add an Issuer and a Revocation card, so that you no need to access WUI to manage RFID cards any more.

Issuer	A manager card to issuing RFID cards
Revocation	A manager card to revoking RFID cards

Add Card Issuer steps:

- 1) Click "Add button" in the "administrator table" option.
- 2) Input the ID of the FRID Card(SN), select Type= Issuer. If you do not know the ID, see the below introduction please.

Card Issuer usage:

- 1) Put issuer card to the reader of the phone, you'll hear voice "du~".
- 2) Put these cards that need to give relay permission in the reader of the phone. One by one.
- 3) Put issuer card to the reader of the phone, done.

Add Card Revocation steps:

- 1) Click "Add button" in the "administrator table" option.
- 2) Input the ID of the FRID Card(SN), select Type= Revocation. If you do not know the ID, see the below introduction please.

Card Revocation usage:

- 1) Put Revocation card to the reader of the phone, you'll hear voice "du~".
- 2) Put these cards that need to give relay permission in the reader of the phone. One by one.
- 3) Put Revocation card to the reader of the phone, you'll hear voice "du~", done.

How to check the ID of the RFID Card in the Web user interface:

- 1) Set card reader state=Card Issuing.
- 2) Put the card in the reader of the phone.
- 3) Refresh the Web page, you'll see a new message in the "Door Card Table", copy it's ID.
- 4) Set card reader state=Card Revoking.
- 5) Put the card in the reader of the phone, done.

4.2 Press key/Input/ServerControl/DTMF/TouchKey management.



Press key	Press the dial button to trigger the relay.
Input1/2	Shortcut the input1 logic to trigger the relay. See the diagram
Server Control	Use API command to trigger the relay. Ask us for dev manual please.
DTMF Number	Pressing DTMF key to trigger the relay when the phone talking.
Door Card	Using RFID Card trigger the relay.
Touch key Open	Pressing digit passwords to trigger the relay.
Short Circuit time	The relay circuit timer.

Press key diagram:



5. Brief pictures for application environment

The following pictures introduce the practical application of IP intercom. Take door security and fire protection for example. More compatibility application is subject to actual test.

5.1 Door security system application

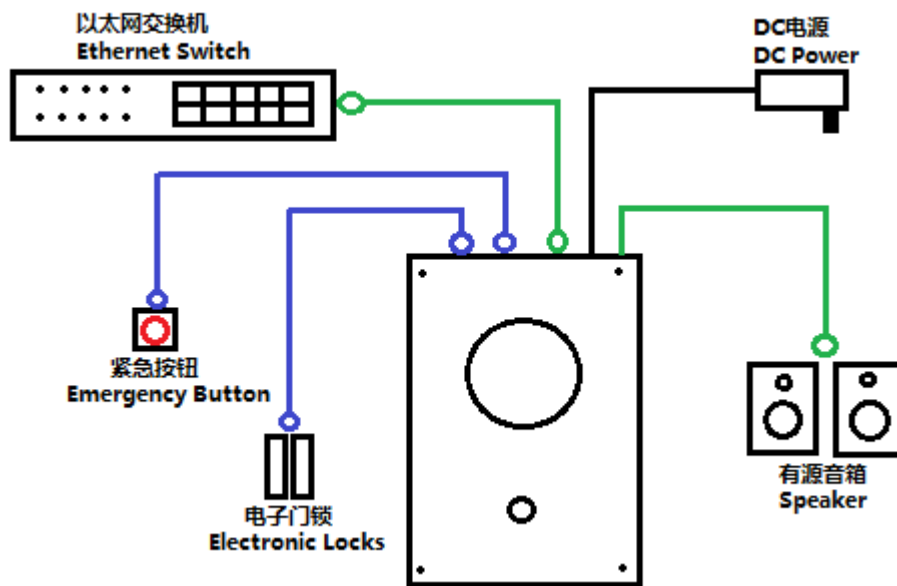

5.2 Fire protection system application

